

Introducing...

The New **AGBAY JR.** Double Blade Cake Leveling Tool

The Most Accurate and Precise Cake Leveling and Torting Tool designed exclusively for the Baking Professional who demands accuracy as well as ease of use



**Flat and Parallel Layers
(as thin as 1/8") Every Time!**



The Agbay Jr. Double Blade

- Cuts up to a 12 inch cake including 1/2 sheet cakes
- Height adjustments from 1/4" up to 4 1/2" high
- Same high quality materials and workmanship as the Professional Agbay Cake Leveler
- Two blades allow you to level and split in one simple step
- Designed for bakeries that level and split 25, 50, or up to 200 cakes a day with accuracy and ease
- Includes cleaning tool and blade guards

Advanced frame design keeps the blade under tension to prevent climbing or digging while cutting.

Super sharp double edged serrated stainless steel blades cut through all types of cakes, including fruits and nuts with ease.

Easy to read blade scale for accurate measurements.

Sturdy 1/4" stainless steel rods for rigid support.

Knobs for quick and easy height adjustments.

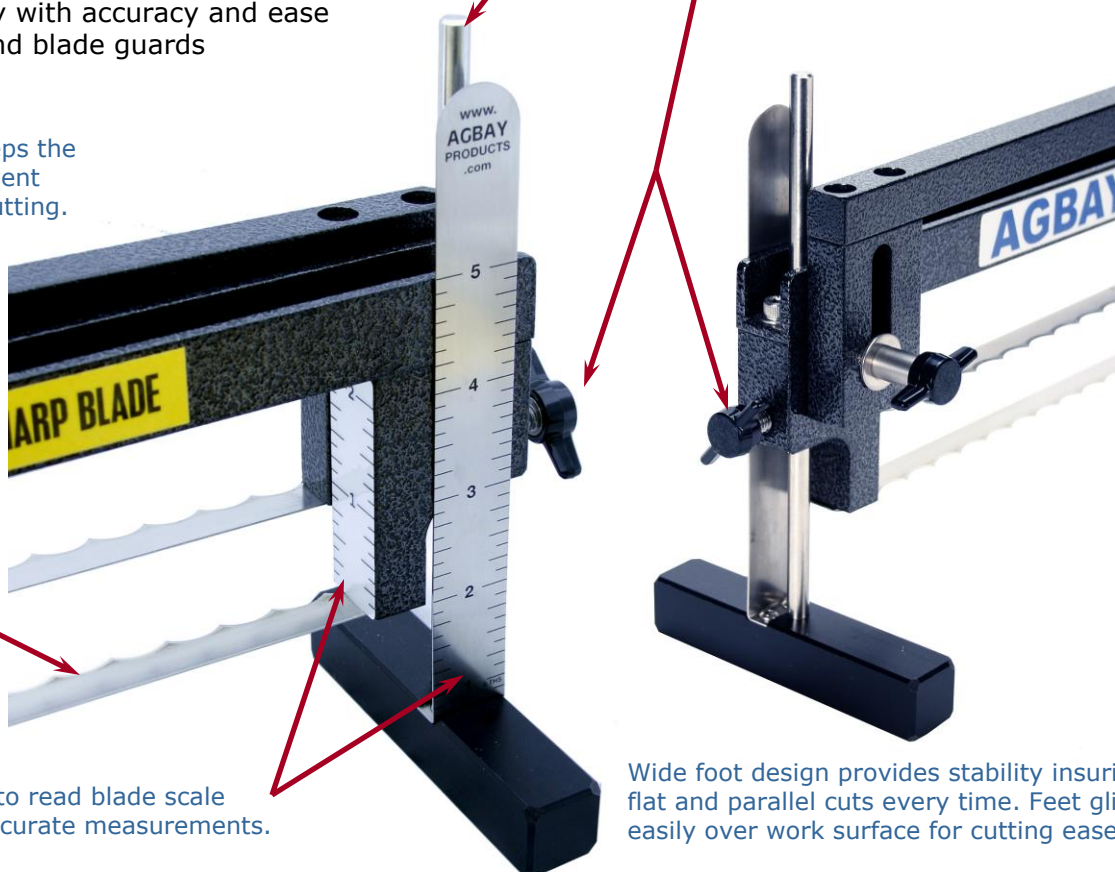

Wide foot design provides stability insuring flat and parallel cuts every time. Feet glide easily over work surface for cutting ease.



MADE IN THE U.S.A

AGBAY PRODUCTS

25 Browning Pond Rd. • Spencer, MA 01562

Tel: 508-753-5169 • Fax: 508-885-8127

www.agbayproducts.com • maureen@agbayproducts.com